

SIGHT FLOW INDICATOR

SERIES : SC / R - 1500

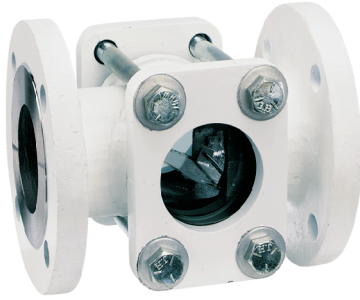

SPINK CONTROLS make Sight Flow Indicators which are most commonly used for monitoring liquid flow in pipelines without compromising the integrity of the piping system. Visual observation and supervision of the process flow stream are two of the main concerns. Single / double window constructions, Sight Flow Indicators are available in various figures & material. CS / SS made bodies with Toughened borosilicate Glass Windows and standard units in flanged / threaded connections provide immunity at higher temperature & pressures. These offer a quick, reliable and inexpensive way to affirm flow rate and direction, and monitor color and clarity in fluid lines.

TECHNICAL SPECIFICATION

Service	Compatible gases and liquids.
Wetted Materials	Window: tempered glass; Body: carbon steel or 316 SS; Gasket: Buna-N, fluoroelastomer or PTFE;
MOC	M.S./ S.S./P.P/PTFE Lined in FABRICATED OR IC
Type	Glass Window Liquid Flow Indication
Temperature	350°C
Pressure	up to 70 Kg/cm ² other on your request
Line Size	Up to 14 Inches (350 mm) other size is Customize
Glass	Toughened Glass
Version	Double / Single Window Viewing
Connection	Flanged / Threaded.

APPLICATIONS

The basic applications of Sight Flow Indicators are spread across several industries and include measuring levels of water, condensate, coolant, diesel, solvent, chemicals, alcohol, lube oil, juices etc.

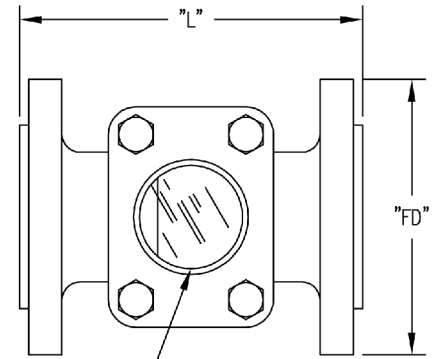

Window
DIMENSION DRAWING

MODEL	SIZE(Inch)	FLANGE TO FLANGE DISTANCE (L)	FLANGE DIAMETER (FD)
SPINK SERIES	1 ½	165	127
	2	200	152
	3	250	191
	4	300	229

All Dimensions are in mm



GEM Seller ID : 8C0F180000397396

303, SIDDHARTH TOWER, MYNOOMAL PATH, KOPRI, THANE(E) - 400 603 MAHARASHTRA, INDIA
 Fax : +91 22 2532 4845 Phone : +91 22 2532 8223 +91 22 2532 8224 Email : info@spinkcontrolsindia.com